



RJ45 HAN Interface

Feature Description

Public

Version 1.6 A

Contents

1	Preface	2
1.1	Overview.....	2
1.2	System Module support	2
1.3	References	3
1.4	Terms and abbreviations	3
2	RJ45 HAN interface.....	4
2.1	HAN interface role in the AMI system	4
2.2	HAN interface HW structure.....	5
2.2.1	Recommended current limiter circuit for the HAN device	5
3	Data profiles.....	7
3.1	HAN interface activation	7
3.2	Data format	7
3.3	NVE data profile.....	8
3.3.1	OBIS code lists.....	8
3.3.2	List sending interval.....	11
3.3.3	Data encryption.....	11
3.3.4	Push setups.....	11
3.3.5	Examples of sent data	13
3.4	EFS data profile.....	13
3.4.1	List sending interval.....	14
3.4.2	Push setup	14
3.4.3	Examples of sent data	15

1 Preface

1.1 Overview

This document describes the physical HAN RJ45 interface on Aidon Energy Service Devices (ESD).

The HAN interface in the devices is activated from the Aidon head-end system for direct connected and current transformer connected Meter types.

The RJ45 HAN interface can be activated according to either NVE or EFS data profile:

- NVE data profile is a DLMS/COSEM based binary protocol according to 62056-7-5 standard and the Norwegian HAN specification.
- EFS data profile is a DLMS/COSEM based binary protocol according to 62056-7-5 standard and the Swedish HAN specification.

See the Aidon System Module types that support the integrated and wired RJ45 HAN from Aidon ESD User Manual (REF6).

1.2 System Module support

The following table lists the supported Aidon System Module types and the System Module software versions which the data profile is supported onwards from.

System Module type	NVE	EFS
Aidon 6474	✓ (2.7→)	✓ (2.9.552→)
Aidon 6475		
Aidon 6476		
Aidon 6477		
Aidon 6478		
Aidon 6479		
Aidon 6483	✓ (2.7→)	✓ (2.9.552→)
Aidon 6484		

1.3 References

Reference	Description
REF1	IEC 62056-7-5:2016: Electricity metering data exchange - The DLMS/COSEM suite - Part 7-5: Local data transmission profiles for Local Networks (LN)
REF2	IEC 61334-6:2000: Distribution automation using distribution line carrier systems - Part 6: A-XDR encoding rule
REF3	IEC 62056-46:2002+AMD1:2006 CSV Consolidated version: Electricity metering - Data exchange for meter reading, tariff and load control - Part 46: Data link layer using HDLC protocol
REF4	IEC 62056-5-3: Electricity metering data exchange - The DLMS/COSEM suite - Part 5-3: DLMS/COSEM application layer
REF5	EXCERPT DLMS UA Blue Book: COSEM interface classes and OBIS identification system http://dlms.com/documents/Excerpt_BB12.pdf
REF6	Aidon ESD User Manual
REF7	EFS: Branschrekommendation för lokalt kundgränssnitt för elmätare v1.2

1.4 Terms and abbreviations

Term	Description
NVE	Norges vassdrags- og energidirektorat (Norwegian Water Resources and Energy Directorate)
EFS	Energiföretagen Sverige, non-profit industry and special interest organisation for the energy sector.
M-Bus Mini-Master	Role defined in the standard EN 13757-2

2 RJ45 HAN interface

2.1 HAN interface role in the AMI system

The role of the HAN interface in the AMI system is to provide near real time information for the customer of their energy usage.

The following picture shows Energy service device where HAN is available on the front of cover.



Figure 1: HAN interface integrated to ESD.

The following picture shows the installation of the HAN solution with the System Module type that uses the HAN adapter cable.



Figure 2: Example installation of the HAN adapter solution.

2.2 HAN interface HW structure

The Aidon RF2 System Modules have a physical HAN interface which implements the M-Bus Mini-Master according to the M-Bus standard (EN 13757-2) with the exception that only one HAN slave device is supported. The RJ45 connector on the System Modules is either integrated or can be wired outside the Aidon ESD with a HAN adapter. Table 1 presents the pin order of the HAN connector.

Pin	Signal	Description
1	MBUS+	M-Bus Data/Power (12-24V, 30mA max.)
2	GND	-
3	NC	Not connected
4	NC	Not connected
5	NC	Not connected
6	Reserved	Do not connect
7	Reserved	Do not connect
8	GND	-

Table 1: HAN interface pinout.

The interface supplies power to a connected HAN device up to 700 mW. The interface is protected against short circuits. The Aidon System Module software can turn the power off from the interface in case of fault current.

The interface of the HAN device that is connected to the Aidon ESD must be double isolated from the mains.

Aidon Meter CE-compliance has been tested with a maximum of a 3-meter cable to the RJ45 connector. Aidon's liability does not apply with longer cable.

2.2.1 Recommended current limiter circuit for the HAN device

The HAN interface is protected against a fault current. The protection is implemented using an over-current detector circuit, which triggers at just above 30 mA. If the current is above the 30-mA limit for $\sim 50 \mu\text{s}$, the HAN interface is shut down. After a 1-minute delay, the interface is re-enabled. This protection scheme limits the peak power that can be taken from the interface to 700 mW and minimizes the wasted power during a fault condition.

To prevent the HAN device from taking excessive peak currents from the interface, it is required to store the peak energy needed for the application at the device side. For this purpose, Aidon recommends that the following *constant current charge circuit* is used before the HAN device's energy storage capacitor (C1).

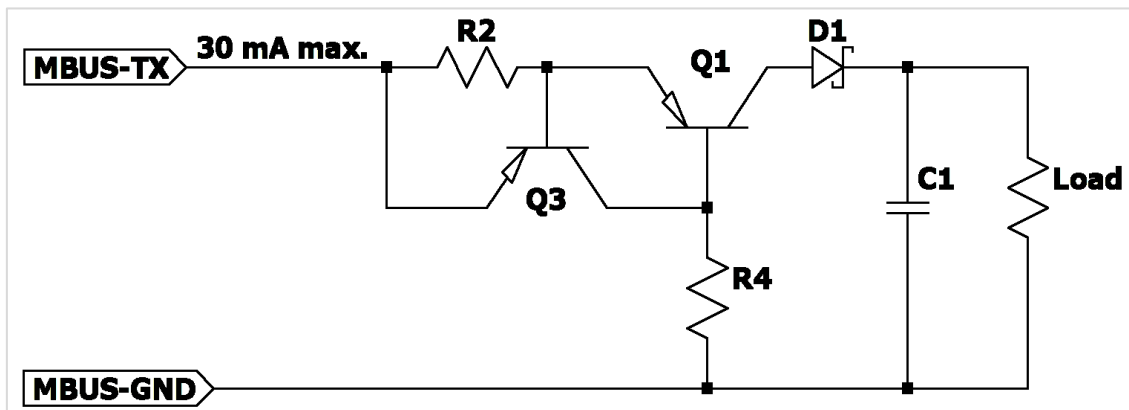

Figure 3: Recommended constant current charge circuit for a HAN device.

3 Data profiles

3.1 HAN interface activation

By default, the interface or even the power supply to the HAN device is not activated. The activation can be done from the Aidon head-end system.

3.2 Data format

HAN data packets are sent inside an HDLC frame. The following COSEM classes are used:

- Data (class_id 1)
- Register (class_id 3)
- Clock (class_id 8)

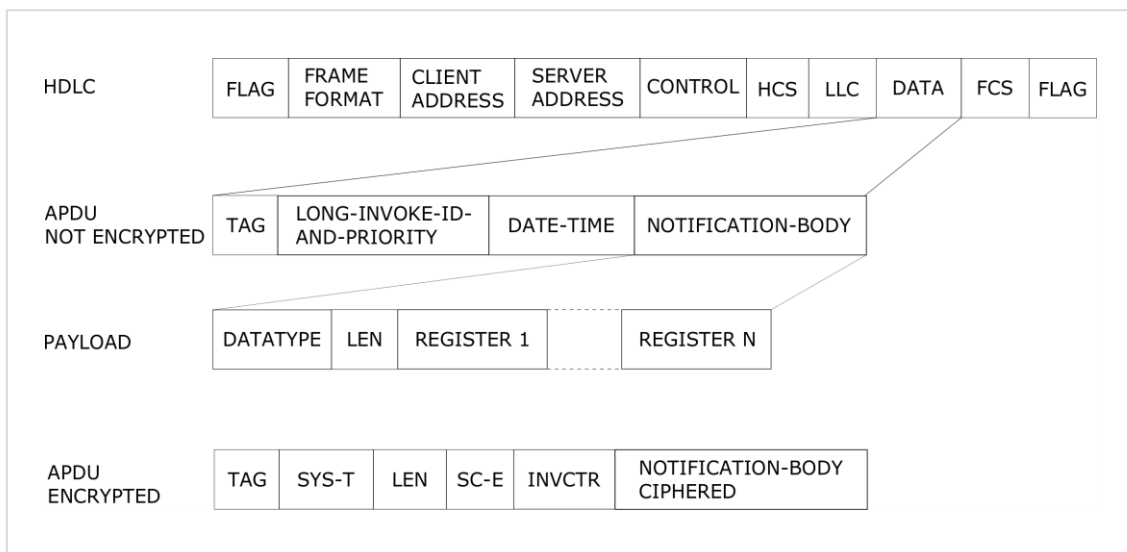

Figure 4: Data format

3.3 NVE data profile

3.3.1 OBIS code lists

Norwegian HAN specification – OBIS List Information			
Item	Description	Value	Remarks
A	File name	Aidon_V0001.xlsx	Filename: OBIS List identifier.xlsx. Format for publication is pdf.
B	List version - date	10.05.2016	DD.MM.YYYY
C	OBIS List version identifier	AIDON_V0001	Shall be identical to the corresponding OBIS code value in the meter
D	Meter type	Aidon 65XX	1P 6515, 3P3W 6525, 3P4W 6534, 3P3W CT 6540, 3P4W CT 6550, 3P4W CT/VT 6560
E	Number of metering systems	1,2,3	(1,2,3)
F	Direct connected (DC) meter	Yes, No	
G	Current transformer connected (CT) meter	Yes, No	
H	Voltage (V)	1x230, 3x230, 3x230/400	(1x 230, 3x230, 3x230/400)
I	Current I _{max} (A)	6, 100	(6, 80, 100 A) I _{max} on the meter nameplate
J	Baud rate M-Bus (HAN)	2400	
K	List 1 Stream out every	2.5 seconds	The value is measured between the messages
L	List 2 Stream out every	10 seconds	The values are measured between the messages
M	List 3 Stream out every	1 hour	The values are generated at XX:00:00 and streamed out from the HAN interface 10 second later (XX:00:10)
N	HAN maximum power to HEMS (mW)	700 mW	The largest power that the customer equipment (HEMS or display) can consume from the meter HAN interface
O	HAN maximum current to HEMS (mA)	30 mA	

Table 2: NVE-HAN information.

Norwegian HAN specification – OBIS Codes												
OBIS List version identifier: AIDON_V0001												
List number			OBIS Code group value						Object name	Attributes		Item
1	2	3	A	B	C	D	E	F		Unit	Data type	Numb
1			1	0	1	7	0	255	Active power+ (Q1+Q4)	kW	double-long-unsigned	1
	1	1	1	1	0	2	129	255	OBIS List version identifier		visible-string	2
	2	2	0	0	96	1	0	255	Meter ID (GIAI GS1 16 digit)		visible-string	3
	3	3	0	0	96	1	7	255	Meter type		visible-string	4
	4	4	1	0	1	7	0	255	Active power+ (Q1+Q4)	kW	double-long-unsigned	5
	5	5	1	0	2	7	0	255	Active power - (Q2+Q3)	kW	double-long-unsigned	6
	6	6	1	0	3	7	0	255	Reactive power + (Q1+Q2)	kVAr	double-long-unsigned	7
	7	7	1	0	4	7	0	255	Reactive power - (Q3+Q4)	kVAr	double-long-unsigned	8
	8	8	1	0	31	7	0	255	IL1 Current phase L1	A	long-signed	9
	9	9	1	0	51	7	0	255	IL2 Current phase L2	A	long-signed	10
	10	10	1	0	71	7	0	255	IL3 Current phase L3	A	long-signed	11
	11	11	1	0	32	7	0	255	UL1 Phase voltage 4W meter, Line voltage 3W meter	V	long-unsigned	12
	12	12	1	0	52	7	0	255	UL2 Phase voltage 4W meter, Line voltage 3W meter	V	long-unsigned	13
	13	13	1	0	72	7	0	255	UL3 Phase voltage 4W meter, Line voltage 3W meter	V	long-unsigned	14
		14	0	0	1	0	0	255	Clock and date in meter		octet-string	15
		15	1	0	1	8	0	255	Cumulative hourly active import energy (A+) (Q1+Q4)	kWh/Wh*	double-long-unsigned	16
		16	1	0	2	8	0	255	Cumulative hourly active export energy (A-) (Q2+Q3)	kWh/Wh*	double-long-unsigned	17
		17	1	0	3	8	0	255	Cumulative hourly reactive import energy (R+) (Q1+Q2)	kVArh/VArh*	double-long-unsigned	18
		18	1	0	4	8	0	255	Cumulative hourly reactive export energy (R-) (Q3+Q4)	kVArh/VArh*	double-long-unsigned	19

Table 3: NVE-HAN OBIS list.

* On Aidon 6560 3P4W CT/VT Meter

Norwegian HAN specification – OBIS Codes	
Item number	Long description OBIS Code
1	Active power in import direction, with resolution of W, Format 4.3 (xxxx,xxx kW)
2	Version number of this OBIS list to track the changes
3	Serial number of the meter point:16 digits 9999999999999999
4	Type number of the meter: "6515, 6525, 6534, 6540, 6550"
5	Active power in import direction, resolution of W, Format 4.3 (xxxx,xxx kW)
6	Active power in export direction, resolution of W, Format 4.3 (xxxx,xxx kW)
7	Reactive power in import direction, resolution of VAr, Format 4.3 (xxxx,xxx kVAr)
8	Reactive power in export direction, resolution of VAr, Format 4.3 (xxxx,xxx kVAr)
9	0.5 second RMS current L1, resolution of 0.1 A, format 3.1 (xxx.x A) (3P3W current between L1 and L2 and part from current between L1 and L3)
10	0.5 second RMS current L2, resolution of 0.1 A, format 3.1 (xxx.x A) (3P3W N/A)
11	0.5 second RMS current L3, resolution of 0.1 A, format 3.1 (xxx.x A) (3P3W current between L2 and L3 and part from current between L1 and L3)
12	0.5 second RMS voltage L1, resolution of 0.1 V, format 3.1 (xxx.x V) (3P3W line voltage L1-L2)
13	0.5 second RMS voltage L2, resolution of 0.1 V, format 3.1 (xxx.x V) (3P3W line voltage L1-L3)
14	0.5 second RMS voltage L3, resolution of 0.1 V, format 3.1 (xxx.x V) (3P3W line voltage L2-L3)
15	Local date and time of Norway
16	Active energy import, resolution of 10 Wh, format 7.2 (xxxxxxx.xx kWh) Active energy import, resolution of 0.01 Wh, format 7.2 (xxxxxxx.xx Wh) *
17	Active energy export, resolution of 10 Wh, format 7.2 (xxxxxxx.xx kWh) Active energy export, resolution of 0.01 Wh, format 7.2 (xxxxxxx.xx Wh) *
18	Reactive energy import, resolution of 10 VArh, format 7.2 (xxxxxxx.xx kVArh) Reactive energy import, resolution of 0.01 VArh, format 7.2 (xxxxxxx.xx VArh) *
19	Reactive energy export, resolution of 10 VArh, format 7.2 (xxxxxxx.xx kVArh) Reactive energy export, resolution of 0.01 VArh, format 7.2 (xxxxxxx.xx VArh) *

Table 4: NVE-HAN OBIS information.

* On Aidon 6560 3P4W CT/VT Meter

3.3.2 List sending interval

The table below is an example of list sending intervals.

- List 1 is sent every 2.5 seconds
- List 2 is sent every 10 seconds
- List 3 is sent 10 seconds after every full hour
- When the list 3 is sent, lists 1 or 2 is not sent
- When the list 2 is sent, lists 1 or 3 is not sent

Time	List
09:00:00.000	List2
09:00:02.500	List1
09:00:05.000	List1
09:00:07.000	List1
09:00:10.000	List3
09:00:12.500	List1
09:00:15.000	List1
09:00:17.500	List1
09:00:20.000	List2

3.3.3 Data encryption

It is possible to encrypt the data using AES-128 keys. Key handling between the devices and the system is out of the scope in this feature.

3.3.4 Push setups

The following chapters describe the push setups for AIDON_V0001 lists. COSEM objects that do not exist for a specific meter type, are not pushed.

3.3.4.1 List 1

COSEM object	class_id	OBIS code	Attribute
Active power+ (Q1+Q4)	3	1-1:1.7.0.255	0

3.3.4.2 List 2

COSEM object	class_id	OBIS code	Attribute
Active power+ (Q1+Q4)	3	1-0:1.7.0.255	0
OBIS List version identifier	1	1-1:0.2.129.255	0
Meter ID (GIAI GS1 16-digit)	1	0-0:96.1.0.255	0
Meter type	1	0-0:96.1.7.255	0
Active power+ (Q1+Q4)	3	1-0:1.7.0.255	0
Active power - (Q2+Q3)	3	1-0:2.7.0.255	0
Reactive power + (Q1+Q2)	3	1-0:3.7.0.255	0
Reactive power - (Q3+Q4)	3	1-0:4.7.0.255	0
IL1 Current phase L1	3	1-0:31.7.0.255	0
IL2 Current phase L2**	3	1-0:51.7.0.255	0
IL3 Current phase L3*	3	1-0:71.7.0.255	0
UL1 Phase voltage 4W meter, line voltage 3W meter	3	1-0:32.7.0.255	0
UL2 Phase voltage 4W meter, line voltage 3W meter*	3	1-0:52.7.0.255	0
UL3 Phase voltage 4W meter, line voltage 3W meter*	3	1-0:72.7.0.255	0

3.3.4.3 List 3

Data	class_id	OBIS code	Attribute
Active power+ (Q1+Q4)	3	1-0:1.7.0.255	0
OBIS List version identifier	1	1-1:0.2.129.255	0
Meter ID (GIAI GS1 16-digit)	1	0-0:96.1.0.255	0
Meter type	1	0-0:96.1.7.255	0
Active power+ (Q1+Q4)	3	1-0:1.7.0.255	0
Active power - (Q2+Q3)	3	1-0:2.7.0.255	0
Reactive power + (Q1+Q2)	3	1-0:3.7.0.255	0
Reactive power - (Q3+Q4)	3	1-0:4.7.0.255	0
IL1 Current phase L1	3	1-0:31.7.0.255	0
IL2 Current phase L2**	3	1-0:51.7.0.255	0
IL3 Current phase L3*	3	1-0:71.7.0.255	0
UL1 Phase voltage 4W meter, line voltage 3W meter	3	1-0:32.7.0.255	0
UL2 Phase voltage 4W meter, line voltage 3W meter*	3	1-0:52.7.0.255	0
UL3 Phase voltage 4W meter, line voltage 3W meter*	3	1-0:72.7.0.255	0
Clock and date in meter	8	0-0:1.0.0.255	1,2
Cumulative hourly active import energy (A+) (Q1+Q4)	3	1-0:1.8.0.255	0
Cumulative hourly active export energy (A-) (Q2+Q3)	3	1-0:2.8.0.255	0
Cumulative hourly reactive import energy (R+) (Q1+Q2)	3	1-0:3.8.0.255	0

Cumulative hourly reactive export energy (R-) (Q3+Q4)	3	1-0:4.8.0.255	0
---	---	---------------	---

* Not available on 1-phase meters

** Not available on 3-phase 3-wire meters and 1-phase meters

3.3.5 Examples of sent data

3.3.5.1 List 2 from 1-phase ESD

```
7e a0d2 41 0883 13 82d6 e6e700
0f 40000000 00
0109
0202 0906 0101000281ff 0a0b 4149444f4e5f5630303031
0202 0906 0000600100ff 0a10 37333539393932383930393431373432
0202 0906 0000600107ff 0a04 36353135
0203 0906 0100010700ff 06 00000552 0202 0f00 161b
0203 0906 0100020700ff 06 00000000 0202 0f00 161b
0203 0906 0100030700ff 06 000003e4 0202 0f00 161d
0203 0906 0100040700ff 06 00000000 0202 0f00 161d
0203 0906 01001f0700ff 10 005d 0202 0fff 1621
0203 0906 0100200700ff 12 09c4 0202 0fff 1623
e0c4 7e
```

3.4 EFS data profile

The following table lists the available measurements that are according to the *Branschrekommendation för lokalt kundgränssnitt för elmätare* [REF7].

Data	Unit
Meter's time and date	N/A
Cumulative hourly active import energy (A+) (Q1+Q4)	kWh
Cumulative hourly active export energy (A-) (Q2+Q3)	kWh
Cumulative hourly reactive import energy (R+) (Q1+Q2)	kVArh
Cumulative hourly reactive export energy (R-) (Q3+Q4)	kVArh
Momentary Active power + (Q1+Q4)	kW
Momentary Active power - (Q2+Q3)	kW
Momentary Reactive power + (Q1+Q2)	kVAr
Momentary Reactive power - (Q3+Q4)	kVAr
Momentary Active power + (L1)	kW
Momentary Active power - (L1)	kW
Momentary Active power + (L2) *	kW
Momentary Active power - (L2) *	kW

Data	Unit
Momentary Active power + (L3) *	kW
Momentary Active power - (L3) *	kW
Momentary Reactive power + (L1)	kVAr
Momentary Reactive power - (L1)	kVAr
Momentary Reactive power + (L2) *	kVAr
Momentary Reactive power - (L2) *	kVAr
Momentary Reactive power + (L3) *	kVAr
Momentary Reactive power - (L3) *	kVAr
Momentary RMS Phase voltage L1	V
Momentary RMS Phase voltage L2 *	V
Momentary RMS Phase voltage L3 *	V
Momentary RMS Current phase L1	A
Momentary RMS Current phase L2 *	A
Momentary RMS Current phase L3 *	A

* Not available on 1-phase meters

3.4.1 List sending interval

When the Swedish HAN interface is activated, the list is pushed every 10 seconds.

3.4.2 Push setup

The following chapters describe the push setups for AIDON_H0001 lists. COSEM objects that do not exist for a specific meter type, are not pushed.

Data	class ID	OBIS code	Attribute
Clock and date in meter	8	0-0:1.0.0.255	1,2
Cumulative hourly active import energy (A+) (Q1+Q4)	3	1-0:1.8.0.255	0
Cumulative hourly active export energy (A-) (Q2+Q3)	3	1-0:2.8.0.255	0
Cumulative hourly reactive import energy (R+) (Q1+Q2)	3	1-0:3.8.0.255	0
Cumulative hourly reactive export energy (R-) (Q3+Q4)	3	1-0:4.8.0.255	0
Momentary Active power+ (Q1+Q4)	3	1-0:1.7.0.255	0
Momentary Active power - (Q2+Q3)	3	1-0:2.7.0.255	0
Momentary Reactive power + (Q1+Q2)	3	1-0:3.7.0.255	0
Momentary Reactive power - (Q3+Q4)	3	1-0:4.7.0.255	0
Momentary Active power+ (L1)	3	1-0:21.7.0.255	0
Momentary Active power - (L1)	3	1-0:22.7.0.255	0

Data	class ID	OBIS code	Attribute
Momentary Active power+ (L2)*	3	1-0:41.7.0.255	0
Momentary Active power - (L2)*	3	1-0:42.7.0.255	0
Momentary Active power+ (L3)*	3	1-0:61.7.0.255	0
Momentary Active power - (L3)*	3	1-0:62.7.0.255	0
Momentary Reactive power+ (L1)	3	1-0:23.7.0.255	0
Momentary Reactive power - (L1)	3	1-0:24.7.0.255	0
Momentary Reactive power+ (L2)*	3	1-0:43.7.0.255	0
Momentary Reactive power - (L2)*	3	1-0:44.7.0.255	0
Momentary Reactive power+ (L3)*	3	1-0:63.7.0.255	0
Momentary Reactive power - (L3)*	3	1-0:64.7.0.255	0
Momentary RMS Phase voltage L1	3	1-0:32.7.0.255	0
Momentary RMS Phase voltage L2*	3	1-0:52.7.0.255	0
Momentary RMS Phase voltage L3*	3	1-0:72.7.0.255	0
Momentary RMS Current phase L1	3	1-0:31.7.0.255	0
Momentary RMS Current phase L2*	3	1-0:51.7.0.255	0
Momentary RMS Current phase L3*	3	1-0:71.7.0.255	0

* Not available on 1-phase meters

3.4.3 Examples of sent data

3.4.3.1 List from 3-phase ESD

```

7e a243 41 0883 13 85eb e6e700
0f 40000000 00
011b
 0202 0906 0000010000ff 090c 07e30c1001073b28ff8000ff
 0203 0906 0100010700ff 06 00000462 0202 0f00 161b
 0203 0906 0100020700ff 06 00000000 0202 0f00 161b
 0203 0906 0100030700ff 06 000005e3 0202 0f00 161d
 0203 0906 0100040700ff 06 00000000 0202 0f00 161d
 0203 0906 01001f0700ff 10 00000202 0fff 1621
 0203 0906 0100330700ff 10 004b0202 0fff 1621
 0203 0906 0100470700ff 10 00000202 0fff 1621
 0203 0906 0100200700ff 12 09030202 0fff 1623
 0203 0906 0100340700ff 12 09c30202 0fff 1623
 0203 0906 0100480700ff 12 09040202 0fff 1623
 0203 0906 0100150700ff 06 00000000 0202 0f00 161b
 0203 0906 0100160700ff 06 00000000 0202 0f00 161b
 0203 0906 0100170700ff 06 00000000 0202 0f00 161d
 0203 0906 0100180700ff 06 00000000 0202 0f00 161d
 0203 0906 0100290700ff 06 00000462 0202 0f00 161b
 0203 0906 01002a0700ff 06 00000000 0202 0f00 161b
 0203 0906 01002b0700ff 06 000005e2 0202 0f00 161d

```



```
0203 0906 01002c0700ff 06 00000000 0202 0f00 161d
0203 0906 01003d0700ff 06 00000000 0202 0f00 161b
0203 0906 01003e0700ff 06 00000000 0202 0f00 161b
0203 0906 01003f0700ff 06 00000000 0202 0f00 161d
0203 0906 0100400700ff 06 00000000 0202 0f00 161d
0203 0906 0100010800ff 06 00995986 0202 0f00 161e
0203 0906 0100020800ff 06 00000008 0202 0f00 161e
0203 0906 0100030800ff 06 0064ed4b 0202 0f00 1620
0203 0906 0100040800ff 06 00000005 0202 0f00 1620
be40 7e
```